

| ZONE |  | REV | DESCRIPTION | DATE | APPROVED |
|------|--|-----|-------------|------|----------|
|      |  |     |             |      |          |

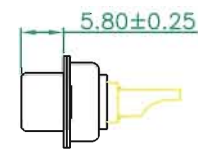
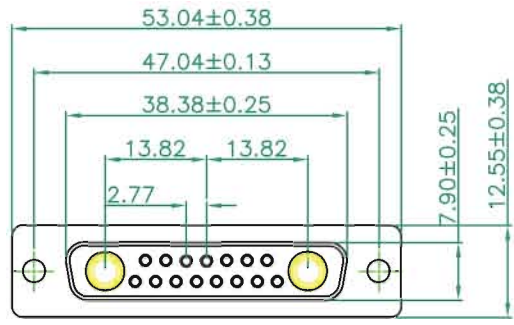

**MATERIALS AND FINISH**

SHELL : STEEL MATERIAL, TIN FINISHED  
 CONNECTOR INSULATOR : PBT THERMOPLASTIC,  
 30% GLASS FILLED, UL 94V-0 RATED, BLACK COLOR  
 HIGH POWER CONTACT MATERIAL: BRASS, GOLD PLATED  
 BOARD LOCKS : BRASS MATERIAL , TIN FINISHED  
 RIVETED INSERT : BRASS MATERIAL , NICKEL FINISHED

**ELECTRICAL CHARACTERISTICS**

HIGH POWER CONTACT CURRENT RATING : 10,20,OR 40 AMPS  
 HIGH POWER CONTACT RESISTANCE : 2.7 MILLIOHMS MAX.  
 DIELECTRIC WITHSTANDING VOLTAGE :  
 1000 V AC FOR 1 MINUTE  
 INSULATION RESISTANCE : 5000 MEGAOHMS MIN.  
 TEMPERATURE RATING : -55°C ~ +125°C

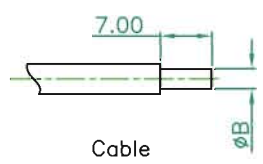
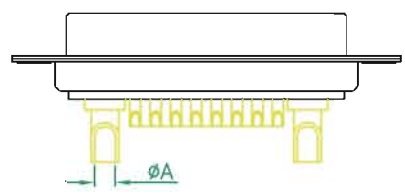

**HOW TO ORDER**

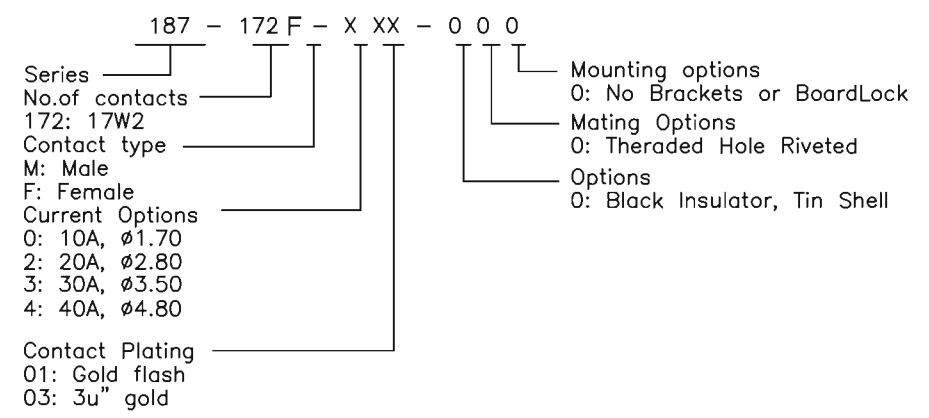

| PART NO.         | Current Rating | Dimension<br>ØA <sup>+0.15</sup> | Wire Size | Dimension<br>ØB <sup>max</sup> |
|------------------|----------------|----------------------------------|-----------|--------------------------------|
| 187-172F-4XX-000 | 40 AMPS        | Ø4.8                             | AWGB-10   | Ø4.8                           |
| 187-172F-3XX-000 | 30 AMPS        | Ø3.5                             | AWG10-12  | Ø3.5                           |
| 187-172F-2XX-000 | 20 AMPS        | Ø2.7                             | AWG12-14  | Ø2.7                           |
| 187-172F-0XX-000 | 10 AMPS        | Ø1.8                             | AWG16-20  | Ø1.8                           |

|            |                    |        |          |
|------------|--------------------|--------|----------|
| TORERANCE  | Drawn              | Stone  | 13.11.23 |
| .X ±0.38   | Designed           | Angela | 13.11.23 |
| .XX ±0.25  | Approved           | Kevin  | 13.11.23 |
| .XXX ±0.15 | Angles+\-5°        |        |          |
| Ver A0     | Machine Pin Solder |        |          |

**ADAMICU®**  
 东莞市亚当电子科技有限公司  
 Adam Electronic Technology Co.,Ltd

SHEET 1/1 Scale: 1:1 RoHS

Part No. 187-172F-XXX-000

TITLE:  
 D-sub High Power  
 Connector 17W2 Female  
 Machine Pin Solder