

REV		DESCRIPTION	DATE	APPROVED

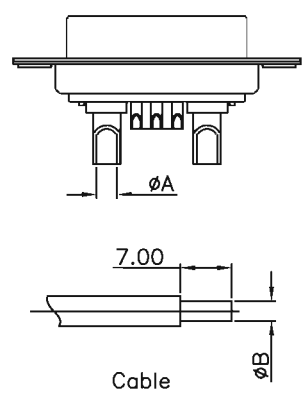
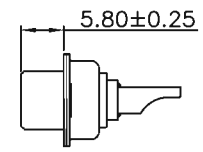
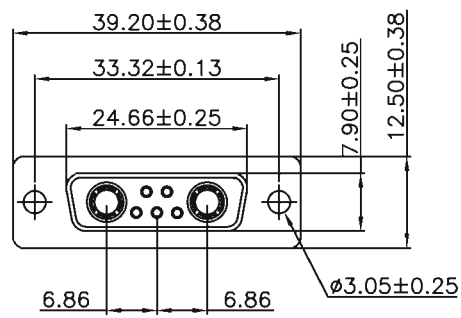

MATERIALS AND FINISH
 SHELL : STEEL MATERIAL, TIN FINISHED
 CONNECTOR INSULATOR : PBT THERMOPLASTIC,
 30% GLASS FILLED, UL 94V-0 RATED, BLACK COLOR
 HIGH POWER CONTACT MATERIAL: BRASS, GOLD PLATED

ELECTRICAL CHARACTERISTICS
 HIGH POWER CONTACT CURRENT RATING :10,20,OR 40 AMPS
 HIGH POWER CONTACT RESISTANCE : 2.7 MILLIOHMS MAX.
 DIELECTRIC WITHSTANDING VOLTAGE :
 1000 V AC FOR 1 MINUTE
 INSULATION RESISTANCE : 5000 MEGAOHMS MIN.
 TEMPERATURE RATING : -55°C ~ +125°C

HOW TO ORDER

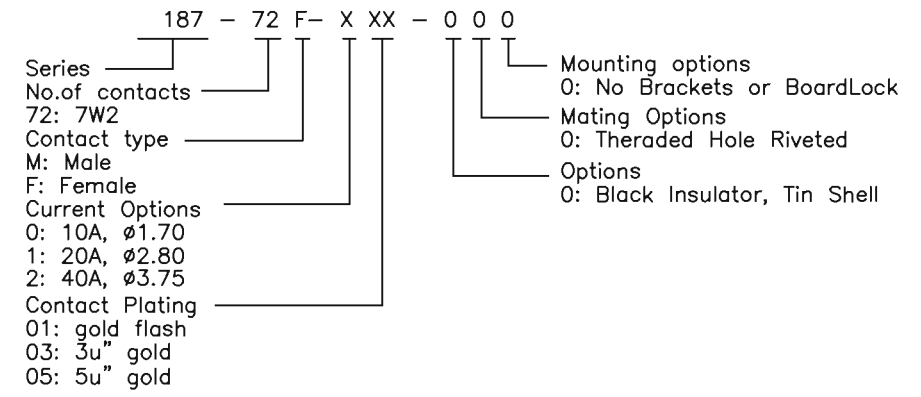

PART NO.	Current Rating	Dimension	Wire Size	Dimension
		ØA ^{+0.15}		ØB ^{max}
187-72F-2XX-000	40 AMPS	Ø4.8	AWG8-10	Ø4.8
187-72F-1XX-000	20 AMPS	Ø2.7	AWG12-14	Ø2.7
187-72F-0XX-000	10 AMPS	Ø1.8	AWG16-20	Ø1.8

TORERANCE	Drawn	Lucy Liu	10.09.01
.X ±0.38	Designed	Lucy Liu	10.09.01
.XX ±0.25	Approved	Raoul	10.09.01
.XXX ±0.15	D-sub High Power 7W2 Solder Connector for cable		
Angles+ \ -5°			
Ver A0	TITLE		

ADAMICU®
东莞市亚当电子科技有限公司
Adam Electronic Technology Co.,Ltd

SHEET 1/1	Scale: 1:1		RoHS
Part No.		187-72F-XXX-000	