

ZONE		REV	DESCRIPTION	DATE	APPROVED

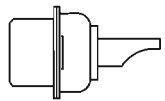

MATERIALS AND FINISH
 SHELL : STEEL MATERIAL, TIN FINISHED
 CONNECTOR INSULATOR : PBT THERMOPLASTIC,
 30% GLASS FILLED, UL 94V-0 RATED, BLACK COLOR
 HIGH POWER CONTACT MATERIAL: BRASS, GOLD PLATED

ELECTRICAL CHARACTERISTICS
 HIGH POWER CONTACT CURRENT RATING :10,20,OR 40 AMPS
 HIGH POWER CONTACT RESISTANCE : 2.7 MILLIOHMS MAX.
 DIELECTRIC WITHSTANDING VOLTAGE :
 1000 V AC FOR 1 MINUTE
 INSULATION RESISTANCE : 5000 MEGAOHMS MIN.
 TEMPERATURE RATING : -55°C ~ +125°C

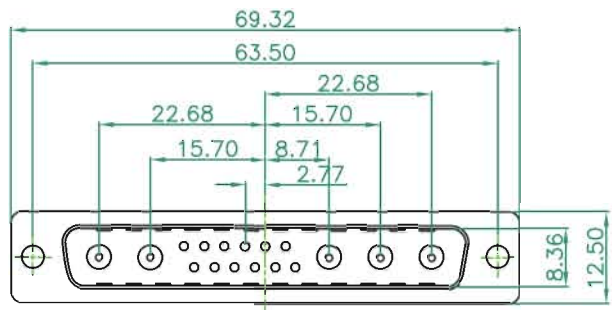
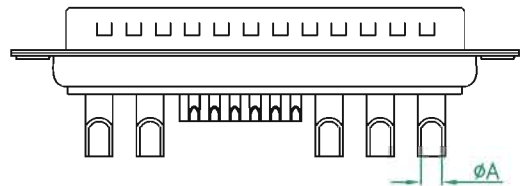

HOW TO ORDER

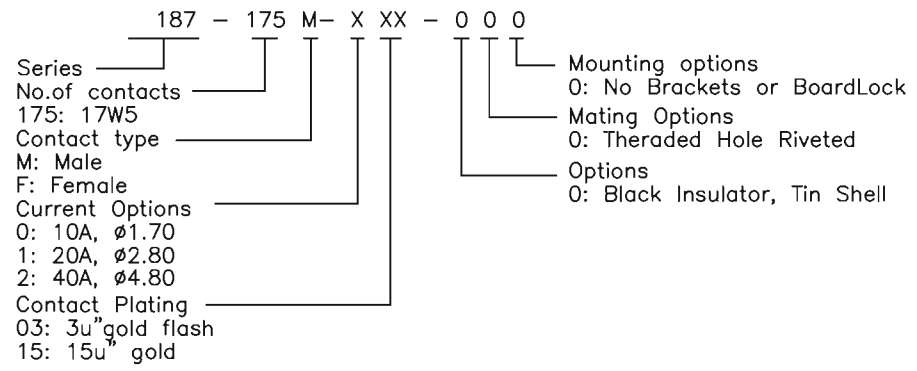

PART NO.	Current Rating	Dimension ϕA
187-175M-4XX-000	40 AMPS	ϕ 4.8
187-175M-3XX-000	30 AMPS	ϕ 3.5
187-175M-2XX-000	20 AMPS	ϕ 2.8
187-175M-0XX-000	10 AMPS	ϕ 1.7

TORERANCE	Drawn	Stone	13.11.26
.X \pm 0.38	Designed	Angela	13.11.26
.XX \pm 0.25	Approved	Kevin	13.11.26
.XXX \pm 0.15	TITLE: Combo D-sub 17W5 Male Machine Pin Solder		
Angles+\-5°	Ver A0		

ADAMICU®
 东莞市亚当电子科技有限公司
 Adam Electronic Technology Co.,Ltd

SHEET 1/1 Scale: 1:1 RoHS

Part No. 187-175M-XXX-000